

**KB 160**

**KB 400**

**CARATTERISTICHE COSTRUTTIVE / CONSTRUCTION FEATURES  
 КОНСТРУКТИВНЫЕ ХАРАКТЕРИСТИКИ / CARACTÉRISTIQUES D'EXÉCUTION**

<b>Corpo pompa</b>	ghisa
<b>Pump body</b>	cast iron
<b>Корпус насоса</b>	чугун
<b>Corps de pompe</b>	fonte
<b>Supporto motore</b>	ghisa
<b>Motor bracket</b>	cast iron
<b>Суппорт двигателя</b>	чугун
<b>Support moteur</b>	fonte
<b>Girante</b>	ottone o Noryl® (KB100÷900 T) ottone (KB750 T÷1500 T)
<b>Impeller</b>	brass or Noryl® (KB100÷900 T) brass (KB750 T÷1500 T)
<b>Рабочее колесо/импеллер</b>	латунь или Noryl® (KB100÷900 T) латунь (KB750 T÷1500 T)
<b>Turbine</b>	laiton ou Noryl® (KB100÷900 T) laiton (KB750 T÷1500 T)
<b>Tenuta meccanica</b>	ceramica-grafite
<b>Mechanical seal</b>	ceramic-graphite
<b>Механическое уплотнение</b>	керамика-графит
<b>Garniture mécanique</b>	céramique-graphite
<b>Albero motore</b>	acciaio AISI 303 acciaio AISI 416 (KB100)
<b>Motor shaft</b>	stainless steel AISI 303 stainless steel AISI 416 (KB100)
<b>Вал двигателя</b>	нержавеющая сталь AISI 303 нержавеющая сталь AISI 416 (KB100)
<b>Arbre moteur</b>	acier AISI 303 acier AISI 416 (KB100)
<b>Temperatura del liquido</b>	girante Noryl®: 0 - 50 °C girante ottone: 0 - 90 °C
<b>Liquid temperature</b>	Noryl® impeller: 0 - 50 °C brass impeller: 0 - 90 °C
<b>Температура жидкости</b>	импеллер из Noryl®: 0 - 50 °C импеллер из латуни: 0 - 90 °C
<b>Température du liquide</b>	turbine en Noryl®: 0 - 50 °C turbine laiton: 0 - 90 °C
<b>Pressione di esercizio</b>	
<b>Operating pressure</b>	max 6 bar (KB100)
<b>Рабочее давление</b>	max 11 bar (KB160-1500 T)
<b>Pression de fonctionnement</b>	

**MOTORE / MOTOR / ДВИГАТЕЛЬ / MOTEUR**

<b>Motore 2 poli a induzione</b>	3~ 230/400V-50Hz 1~ 230V-50Hz
<b>2 pole induction motor</b>	con termoprotettore with thermal protection
<b>2-х полюсный асинхронный двигатель</b>	с тепловой защитой avec protection thermique
<b>Moteur à induction à 2 pôles</b>	
<b>Classe di isolamento</b>	
<b>Insulation class</b>	F
<b>Класс изоляции обмоток</b>	
<b>Classe d'isolation</b>	
<b>Grado di protezione</b>	
<b>Protection degree</b>	IP44
<b>Класс защиты корпуса</b>	
<b>Protection</b>	

Pompe centrifughe bi-giranti adatte alla realizzazione di gruppi di pressurizzazioni per impianti civili e industriali; le due giranti contrapposte garantiscono una elevata prevalenza garantendo comunque una buona portata.

Two impeller centrifugal pumps for constructing pressurisation systems for civil and industrial plant; the two counter-posed impellers guarantee high head with good delivery.

Центробежный насос с двумя рабочими колесами для гражданских и промышленных систем повышения давления, два обратно позиционируемых рабочих колеса обеспечивают высокий напор при хорошей производительности.

Pompes centrifuges à deux turbines, aptes à la réalisation de groupes de surpression pour installations civiles et industrielles; les deux roues opposées garantissent une hauteur manométrique élevée tout en maintenant un débit excellent.

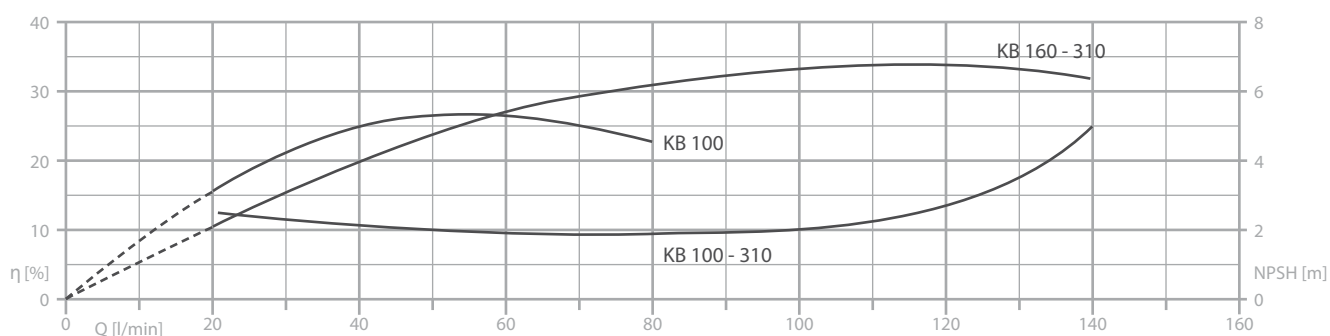
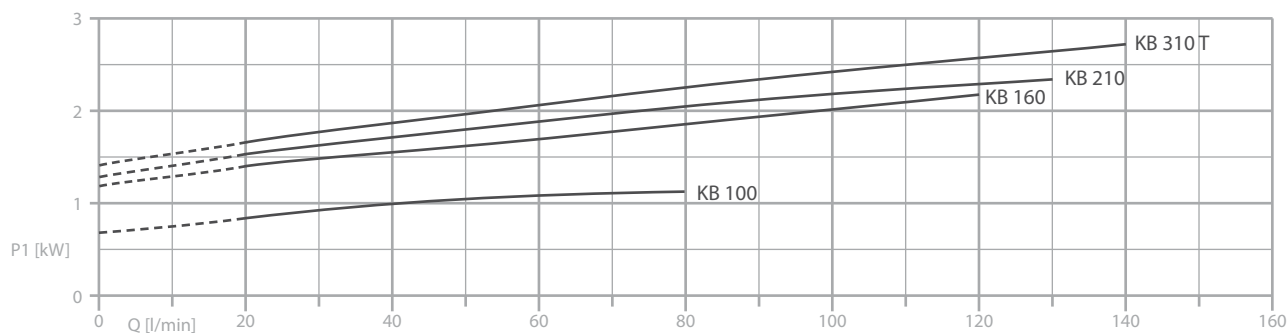
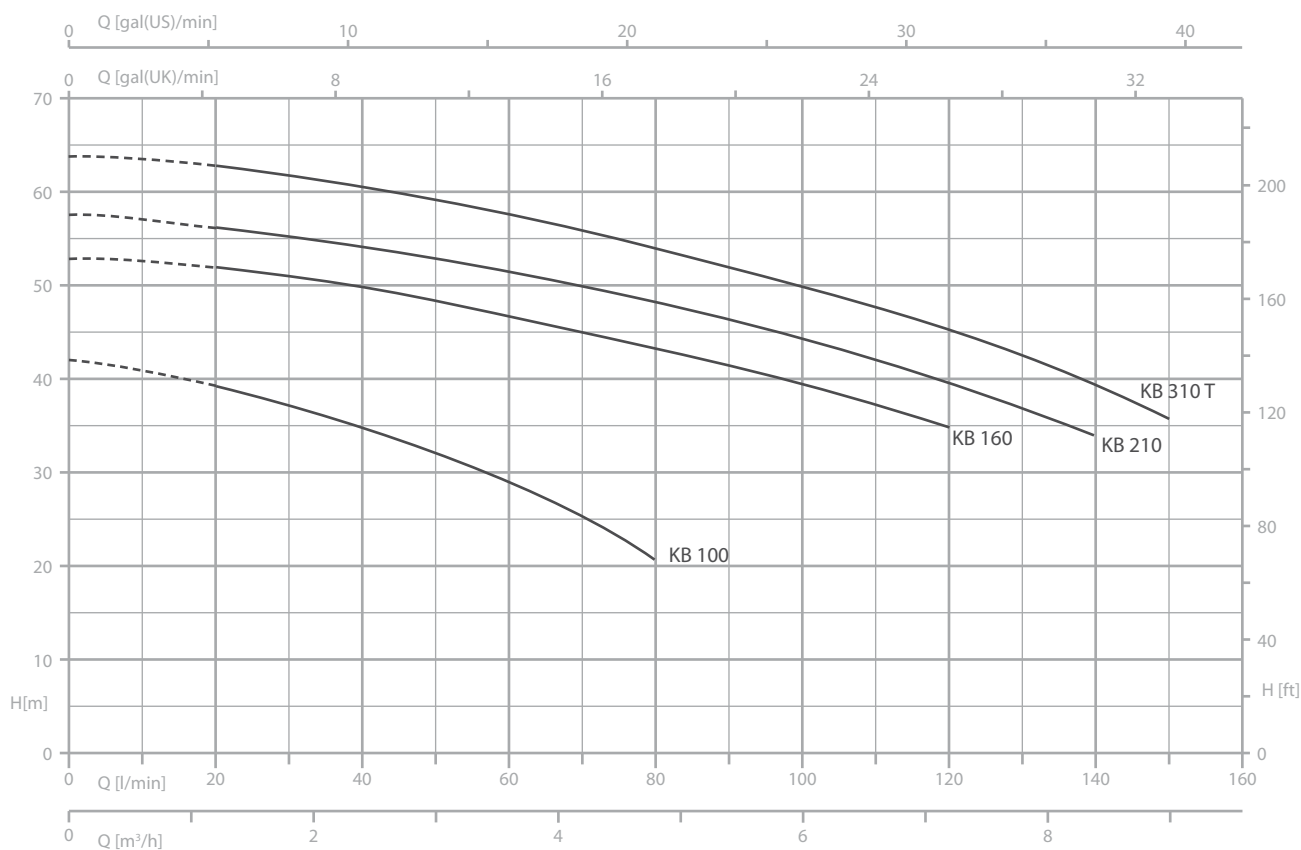

TYPE / ТИП		P2		P1 (kW)		AMPERE / ТОК		Q (m³/h - l/min)										
1~	3~					1~	3~	0	0,6	1,2	1,8	2,4	3,6	4,8	6	7,2	8,4	9
		(HP)	(kW)	1~	3~	1x230 V 50 Hz	3x400 V 50 Hz	H (m)										
KB 100	KB 100 T	1	0,74	1,17	1,15	5,4	2,4	42	40,8	39,4	37,4	34,7	29,2	21	-	-	-	-
KB 160	KB 160 T	1,5	1,1	2,30	2,20	10,2	4,1	53	52,5	52	51	50	46,9	43,3	39,7	35	-	-
KB 210	KB 210 T	2	1,5	2,60	2,45	11,5	4,8	57,3	56,9	56	55,1	54	51,5	48,4	44,4	39,5	34	-
-	KB 310 T	3	2,2	-	2,80	-	5,2	64	63,5	63	61,9	60,6	57,7	54,1	50	45,4	39,4	36

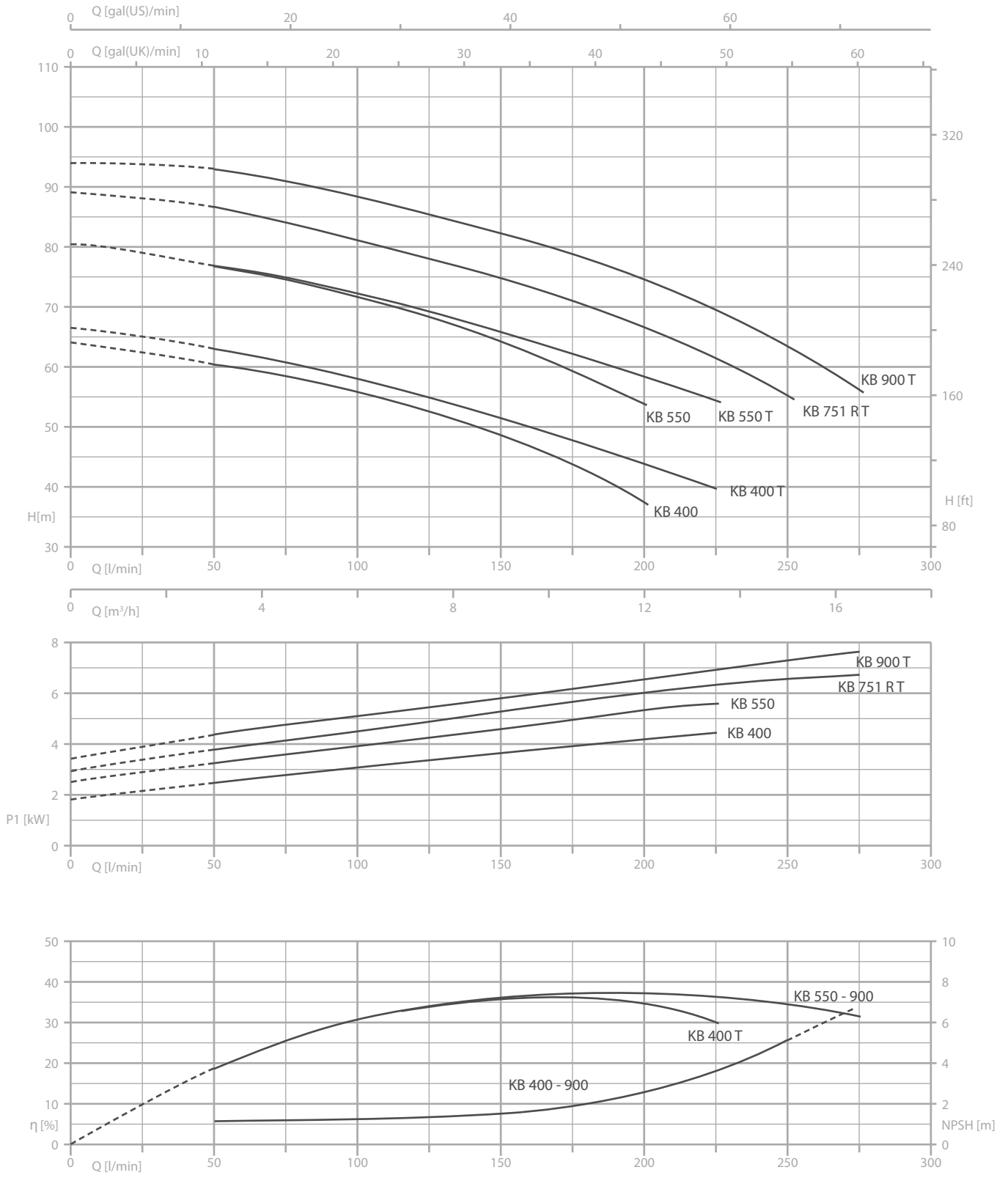

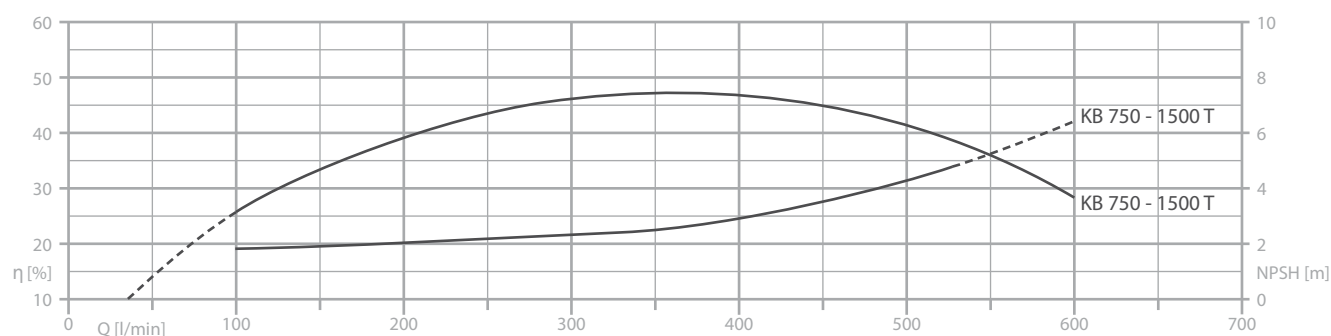
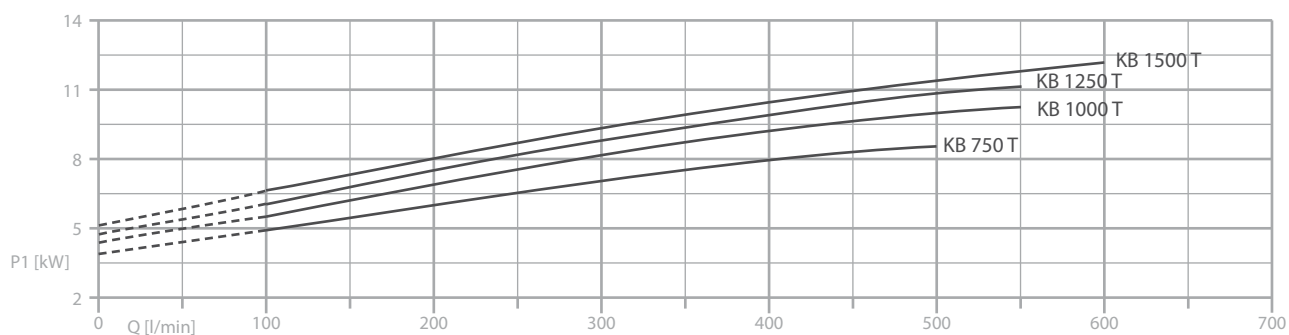
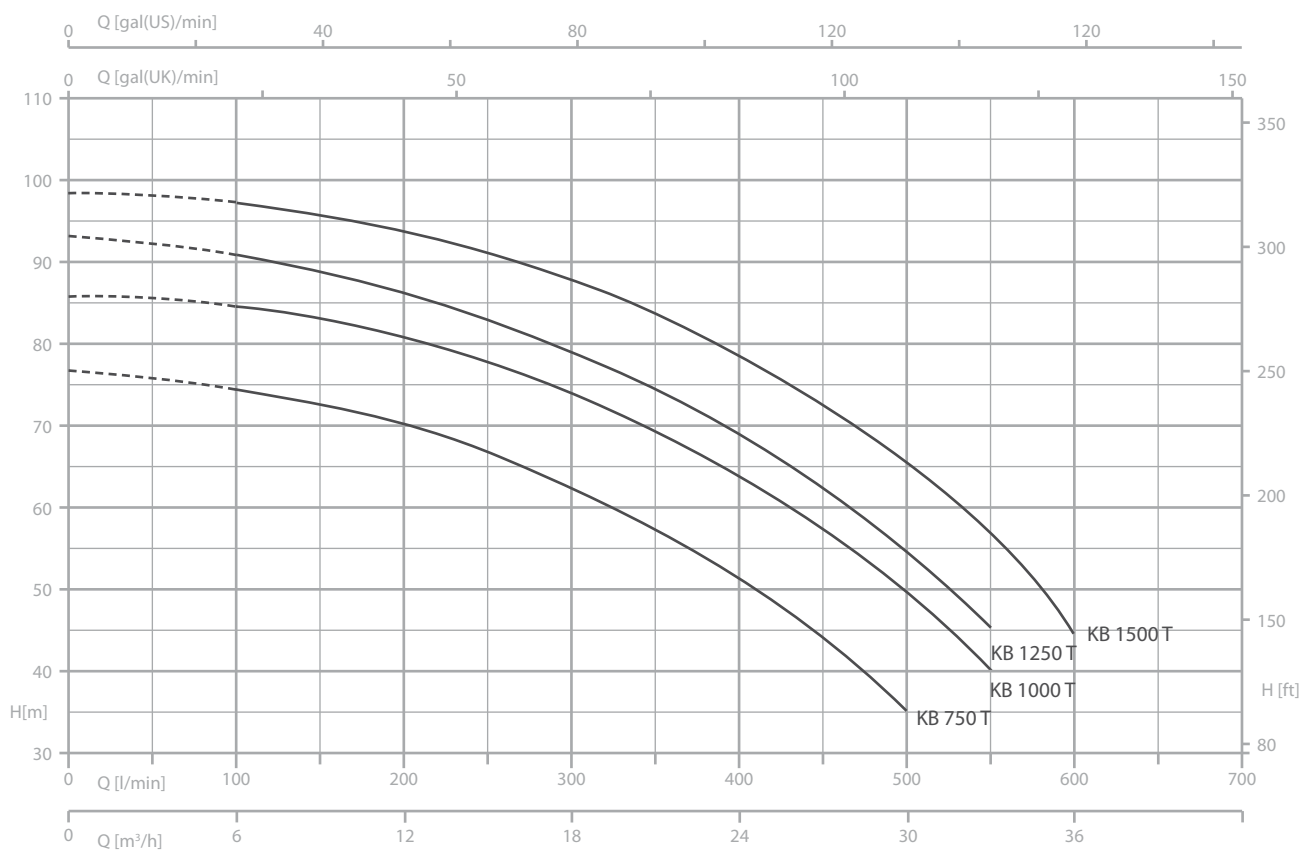

TYPE / ТИП		P2		P1 (kW)		AMPERE / ТОК		Q (m³/h - l/min)															
1~	3~	(HP)	(kW)	1~	3~	1~	3~	0	1,5	3,0	4,5	6,0	7,5	9,0	10,5	12	13,5	15,0	16,5				
						0	25	50	75	100	125	150	175	200	225	250	275						
						1x230V 50 Hz	3x400V 50 Hz	H (m)															
KB 400	-	4	3	4,3	-	19,0	-	64,4	62,7	60,8	58,3	55,6	52,6	48,7	43,5	37,9	-	-	-	-			
-	KB 400 T	4	3	-	4,6	-	7,9	66,9	65,2	63,3	61	58,4	55,2	51,5	47,8	44,3	40,1	-	-	-			
KB 550	-	5,5	4,0	5,7	-	26,0	-	80,4	79,1	77,1	74,5	71,8	68,4	64	59,2	54,1	-	-	-	-			
-	KB 550 T	5,5	4,0	-	5,6	-	9,8	80,4	79,1	77,1	75	72,2	69,4	66	62,4	58,6	54,5	-	-	-			
-	KB 751 R T	7,5	5,5	-	6,8	-	11,6	89,5	88,3	86,7	84,1	81,3	78,3	74,7	71,1	66,9	61,3	55	-	-			
-	KB 900 T	9	6,6	-	7,6	-	13,2	94,2	93,8	92,8	91,2	88,7	85,7	82,5	79,1	75	69,4	63	56	-			

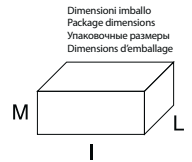
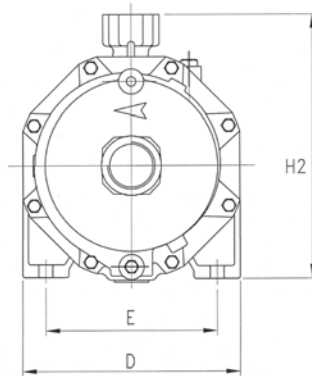
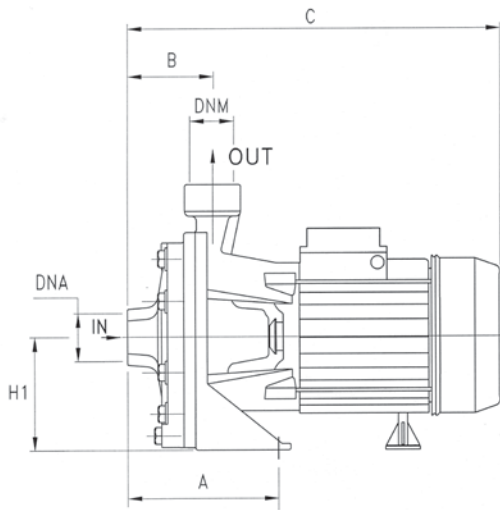

TYPE / ТИП	P2		P1 (kW)	AMPERE / ТОК	Q (m³/h - l/min)							
				3~	0	6	12	18	24	30	33	36
					0	100	200	300	400	500	550	600
3~	(HP)	(kW)	3~	3x400 V 50 Hz	H (m)							
<b>KB 750 T</b>	7,5	5,5	8,5	15	77,0	76,4	70,5	62,8	51,6	36,0	-	-
<b>KB 1000 T</b>	10	7,5	10,3	17,2	86,4	84,8	80,7	74,3	64,0	50,2	40,4	-
<b>KB 1250 T</b>	12,5	9,2	11,1	18,9	93,6	91,0	86,3	79,7	68,5	55,2	46,0	-
<b>KB 1500 T</b>	15	11	12,1	20,4	98,7	97,6	94,2	87,6	78,2	65,6	57,5	40,9



TYPE / ТИП	DIMENSIONS / РАЗМЕРЫ (mm)												
	A	B	C	D	E	H1	H2	DNA	DNM	I	L	M	
<b>KB 100</b>	122	72	328	180	140	98	228	1" G	1" G	350	195	265	15.3
<b>KB 160</b>	115	82	385	210	170	110	265	1"1/4 G	1" G	405	225	295	24.7
<b>KB 210</b>	115	82	385	210	170	110	265	1"1/4 G	1" G	405	225	295	25.6
<b>KB 310</b>	115	82	385	210	170	110	265	1"1/4 G	1" G	405	225	295	25.6
<b>KB 400</b>	145	95,5	463	266	212	135	305	1"1/2 G	1"1/4 G	500	275	350	41
<b>KB 550</b>	145	95,5	463	266	212	135	305	1"1/2 G	1"1/4 G	500	275	350	44.8
<b>KB 751 R T</b>	145	95,5	480	266	212	135	305	1"1/2 G	1"1/4 G	500	275	350	50.5
<b>KB 900 T</b>	145	95,5	480	266	212	135	305	1"1/2 G	1"1/4 G	500	275	350	55
<b>KB 750 T</b>	190	120	605	275	210	150	330	2" G	1"1/4 G	640	310	370	70.5
<b>KB 1000 T</b>	190	120	605	275	210	150	330	2" G	1"1/4 G	640	310	370	77
<b>KB 1250 T</b>	190	120	645	275	210	150	330	2" G	1"1/4 G	640	310	370	85
<b>KB 1500 T</b>	190	120	645	275	210	150	330	2" G	1"1/4 G	640	310	370	92